

MCU Wiring Diagram

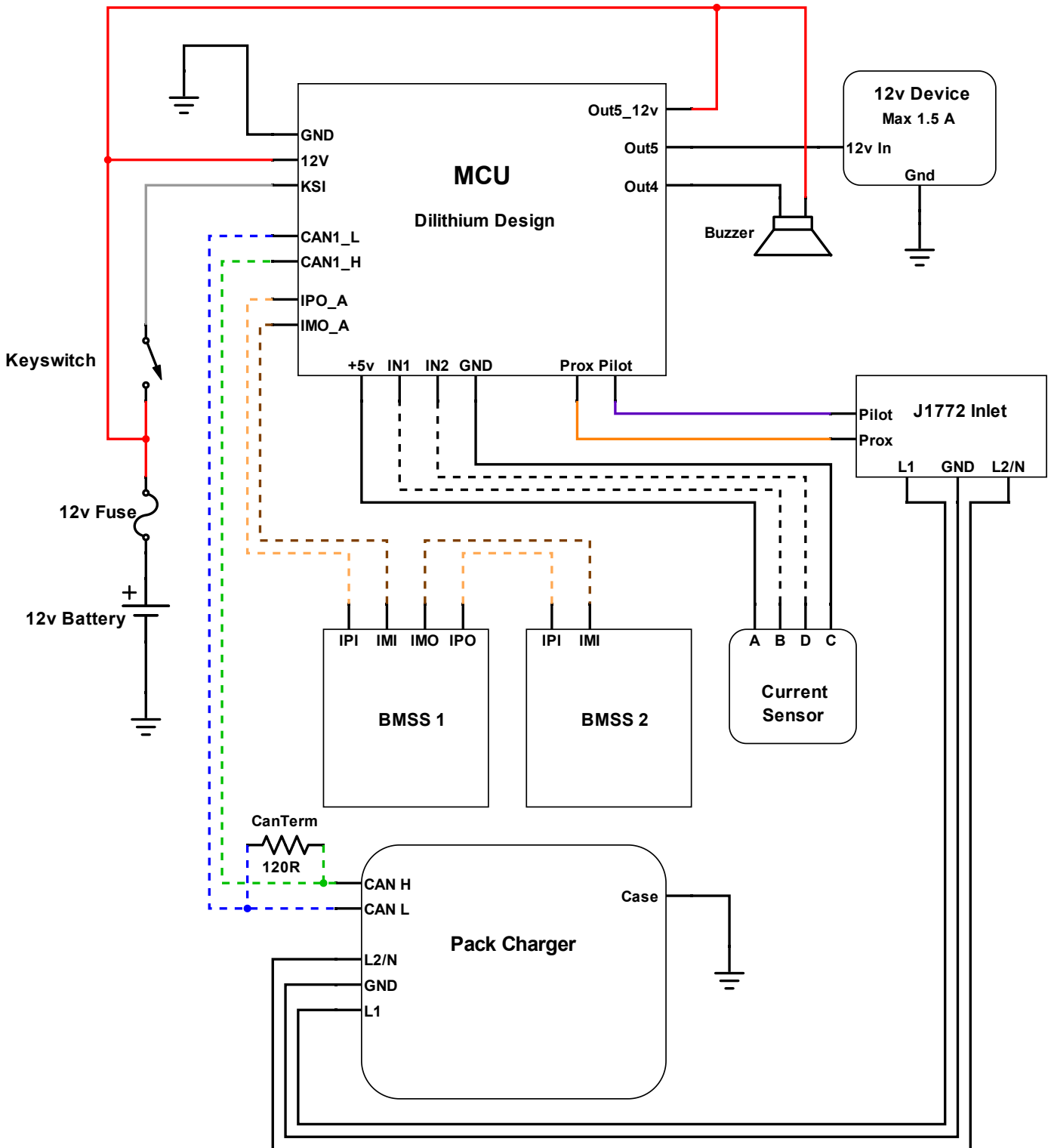

Notes:

- 1) Dashed lines show data transmission - twisted wire pairs recommended for canbus, IP/IM and IN1/IN2 circuits.
- 2) Current Sensor pinouts shown for DHAB S/124 and S/137
- 3) Power circuits should be fused at the source based on wire gauge
- 4) CanTerm is a 120 Ohm 1/4 watt resistor connected near charger