

# *ELCon*

---

---

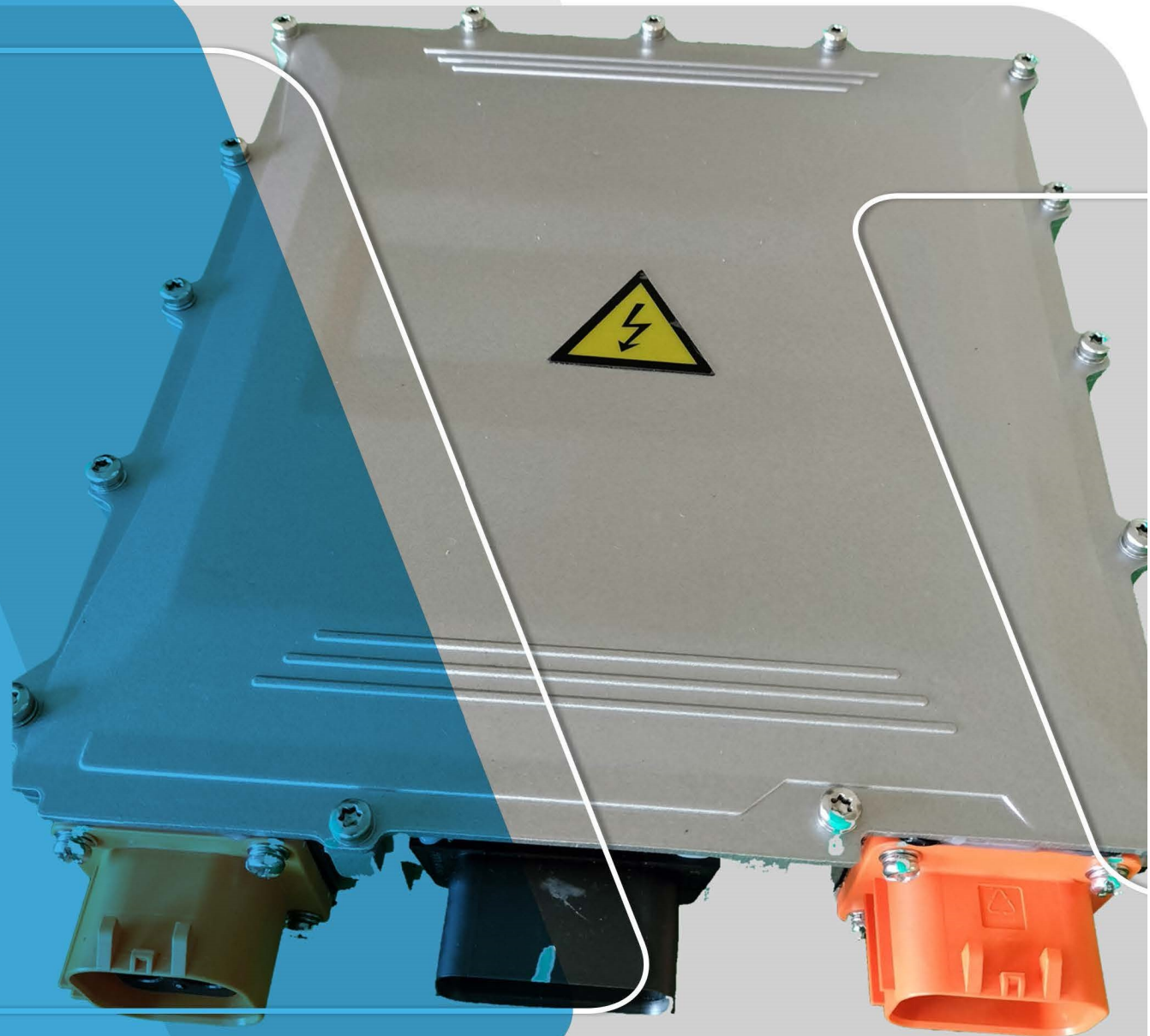

**HK-LF-108-60**

**HK-LF-144-46**

**6.6KW ON-BOARD CHARGER**

**SPECIFICATION MANUAL**

**VERSION 1.0 ISSUE DATE: 2021.1**



---

## Table Of Contents

1 Overview .....	2
1.1 Subject .....	2
1.2 Main features .....	2
2 Charger technical specification .....	3
2.1 Environmental requireme .....	3
2.2 Charger regulatory requirements and reference standards.....	4
3 Charger safety regulations .....	4
4 Charger electrical performance .....	5
4.1 Input Performance .....	5
4.2 Output Performance .....	5
4.3 Low voltage output performance .....	5
4.4 Control Interface.....	6
4.5 Other .....	6
5 Protection functions .....	6
6 Control Interface .....	7
6.1 Low voltage connector and pins definition .....	7
6.1.1 Connector pins definition .....	7
6.2 High voltage connector and pins definition .....	7
6.2.1 AC input connector .....	7
6.2.2 DC output connector Input connector.....	7
7 Software Requirement .....	8
8 Mechanical Requirements .....	8
8.1 Size and weight .....	8
8.2 Appearance.....	9
8.3 Appearance Requirements .....	10
9 Installation Size .....	10
10 Installation Requirement .....	10
11 Safety Guide.....	11

---

---

## 1. Overview

### 1.1 Subject

HK-MF models OBC is specifically designed for battery powered vehicles. This product boasts the highest obtainable efficiency possible in its class and thus is able to do so with the smallest chassis size. Multiple safeties are present and if cooling is obstructed, internal thermal sensor will cut back charger output until charger cools down to safe level and restarts automatically. With fully sealed electronics, IP67 protection rating is reached which makes these chargers suitable for use in real world operating conditions.

### 1.2 Main Features

1.2.1 Support UDS diagnosis, with CAN wake-up function

1.2.2 Full-sealed process, can reliably work in the temperature of -40°C~60°C

1.2.3 Built-in thermal sensor, shut off when temperature up to 90°C

1.2.4 Protection level with IP67

## 2. Charger Technical Specification

### 2.1 Environmental Specification

▲ Working environmental temperature

Area	Lowest Temperature	Highest Temperature
Global	-40°C	60°C

▲ Storage environmental temperature

Area	Lowest Temperature	Highest Temperature
Global	-40°C	105°C

▲ Humidity: relative humidity 5%~95%, no condensation

▲ Altitude: ≤5000m

▲ Working Sound Level: max when working ≤65dB, meets standard QTC 895-2011

---

---

## 2.2 Charger regulatory requirements and reference standards

The design and manufacture of this product must meet the related Vehicle requirements according to the following regulations and standards:

No.	Standard Code	Standard Name	Remark
1	QC/T 895-2011	Conductive on-board charger of electrical vehicle	/
2	GB/T 30512-2014	Prohibited substances requirement	/
3	GB/T 18387-2008	Limits and measurement methods for electromagnetic field emission intensity of electric vehicles, broadband, 9kHz~30MHz	/
4	GB/T 18384-2015	Safety requirements of electrical vehicle	/
5	GB/T 18487-2015	Electric vehicle conductive charging system	/
6	GB/T 28382-2012	Technical specifications for all-electric passenger vehicles	/
7	GB/T 14023-2011	Limits and methods of measurement for radio disturbance characteristics of vehicles, ships and installations driven by internal combustion engines	/
23	GB/T 18655-2018	EMC technical requirements for electronic components and subsystems of passenger vehicles	/
24	GB/T 18655-2010	Limits and measurement methods for the radio disturbance characteristics of vehicles, ships and internal combustion engines used to protect vehicle-mounted receivers	/

## 3. Charger Safety Regulations Specification

	Condition	Requirement
Grounding resistance test	@25A/AC	$\leq 100\text{m}\Omega$
Input insulation test	@1000V/DC	$\geq 20\text{M}\Omega$
Output insulation test	@1000V/DC	$\geq 20\text{M}\Omega$
Input withstand test	@2000V/AC 1min	Leak current $\leq 15\text{ma}$
Output withstand test	@2000V/AC 1min	Leak current $\leq 10\text{ma}$
Input to Output withstand test	@2000V/AC 1min	Leak current $\leq 10\text{ma}$

---

---

## 4. Charger Electrical Performance

### 4.1 Input

Input	Input voltage range	AC 90~265V
	Frequency	47~63Hz
	Input Current	≤32A
	Power Factor	≥0.98 @ ≥3300W
	Efficiency	≥93% full loading
	Stand-by power consumption	≤5W
	Starting inrush current	≤48A

### 4.2 Output

Nominal Voltage Platform		108V	144V
Output	Output voltage range	70V-155V	95V-202V
	Max output current	60A	46A
	Output power	6600W@220VAC; 3300W@110VAC	
	Output way	CV/CC	
	Efficiency	≥94%	
	CV accuracy	±1%	
	CC accuracy	±2%	
	Ripple voltage coefficient	±5%	
	Output voltage rising time	<5S, overshoot<10%	
	Shut off response time	Current decreased below 10% in 300ms, and decreased to 0A in 500ms	

### 4.3 Low Voltage Output

Low voltage Output	Output way	CV
	Output voltage	12V
	Nominal current	5.5A
	CV accuracy	±2%
	Output Power	≤66W
	Ripple voltage coefficient	≤1%

---

---

#### 4.4 Control Interface

	12V wake-up input	$\leq 10\text{mA}$
	12V wake-up signal output	Max 0.2A
	12V CV	Sleep current $\leq 1\text{mA}$ , peak current $\leq 5\text{A}$
	CAN Communication	yes
	Baud rate	Optional for 125Kbps、250Kbps、500Kbps
	Terminal resistance	120 Ohms

#### 4.5 Other

EMI	Meet GB/T 18487.3-2001 11.3.1 and GB/T 18655-2018
EMD	Meet GB/T 18487.3-2001 11.3.2 and GB/T 18655-2018
Harmonic current	Meet GB 17625.1-2003 6.7.1.1
Protection level	IP67
Vibration resistance	10~25Hz swing 1.2mm, 25—500Hz 30m/S <sup>2</sup> , 8hours each direction
Noise	$\leq 65\text{dB}$ (Class A)
MTBF	150000H

#### 5. Charger Protection Functions

Protection functions	Input over-voltage protection	AC270 $\pm 5\text{V}$
	Input low-voltage protection	AC85 $\pm 5\text{V}$
	Output over-voltage protection	Stop output when exceed the highest voltage $\pm 5\text{V}$
	Output low-voltage protection	Stop output when below the lowest voltage $\pm 5\text{V}$
	Over-temperature protection	Power start to decrease when internal temperature rise to 85°C, shut off when rise to 90°C
	Output short circuit protection	Stop output
	Output polarity reverse protection	yes
	Grounding protection	$\leq 100\text{m}\Omega$
	CAN Communication protection	Automatically stop output when CAN communication fails
	Power-off protection	Yes

---

## 6.2.2 OBC Output

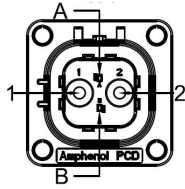

P/N: HVSL362022A Brand: Amphenol

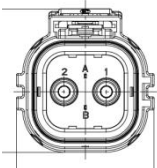
Pin	Function	Rated Current	Definition	Wire cross-sectional area	Mating connector
1	Positive output	60A	/	13mm <sup>2</sup>	P/N: HVSL362062 
2	Negative output		/		
A	/	/	/	/	
B	/		/		

## 7. Software requirements

### 7.1 CAN communication

No.	Items	Technical indicators	Notes
1	Baud rate	250Kbit/s OR 500 Kbit/s	/
2	CAN bus communication protocol	Comply with CAN2.0B specification	/
3	Terminating resistor	120 OHMS	/

## 8. Mechanical requirements

### 8.1 Size and weight

	Length (mm)	Width (mm)	Height (mm)	GW (KG)
Fan-cooled	264.5±3	252±3	100±3	≤5

## 6. Electrical Interface Definition

The interfaces in the charger can be grouped into two categories, one category is low voltage interface, the other is high voltage interface.

Low voltage interface includes control connector

High voltage interface includes AC220V input and DC output

Connectors can be appointed by customer if quantity order is more than 5000pcs.

### 6.1 Low Voltage Signal Connector and Pins Definition

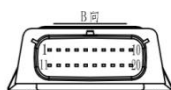

P/N: 348302001 Brand: Molex

Pin	Function	Rated Current	signal type	Mating connector
10	+12V5A	5A	12V5A	
11	CAN_H	0.1A	CAN signal high, digital signal	
12	CAN_L	0.1A	CAN signal low, digital signal	
17	12V GND	5A	12V Ground	
Others	/	NC	Empty pin	

### 6.2 High Voltage Connectors and Pins Definition

#### 6.2.1 AC Input

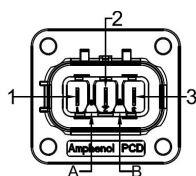

P/N: HVSL633023A Brand: Amphenol

Pin	Function	Rated current	Definition	Wire cross-sectional area	Mating connector
1	Input AC N line	16A	N= Neutral	2.5~4mm <sup>2</sup>	
2	Input AC PE		PE= Ground		
3	Input AC L line		L= Line		
A	/		/		
B					

## 8.2 Appearance



Fan-cooled

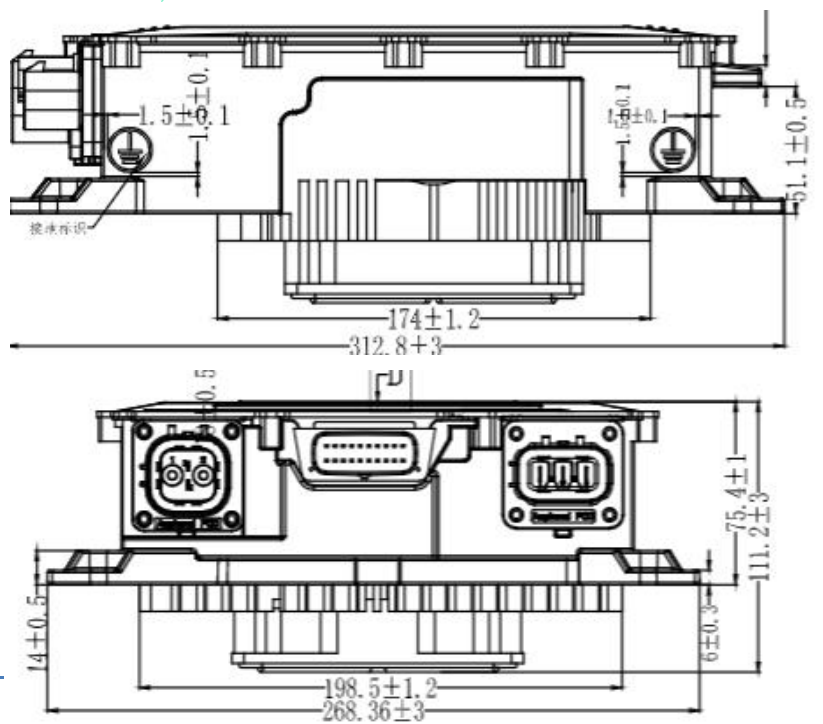
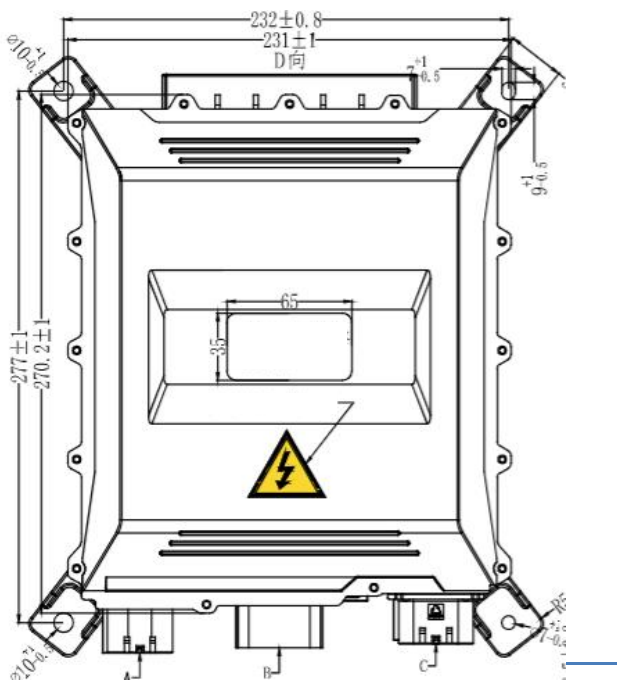

## 9. Installation size

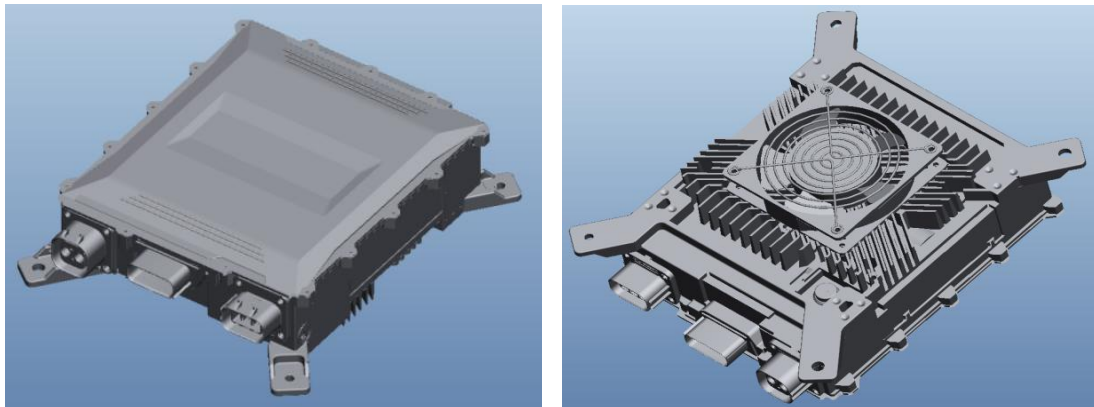

Fan-cooled

## 10. Installation requirements

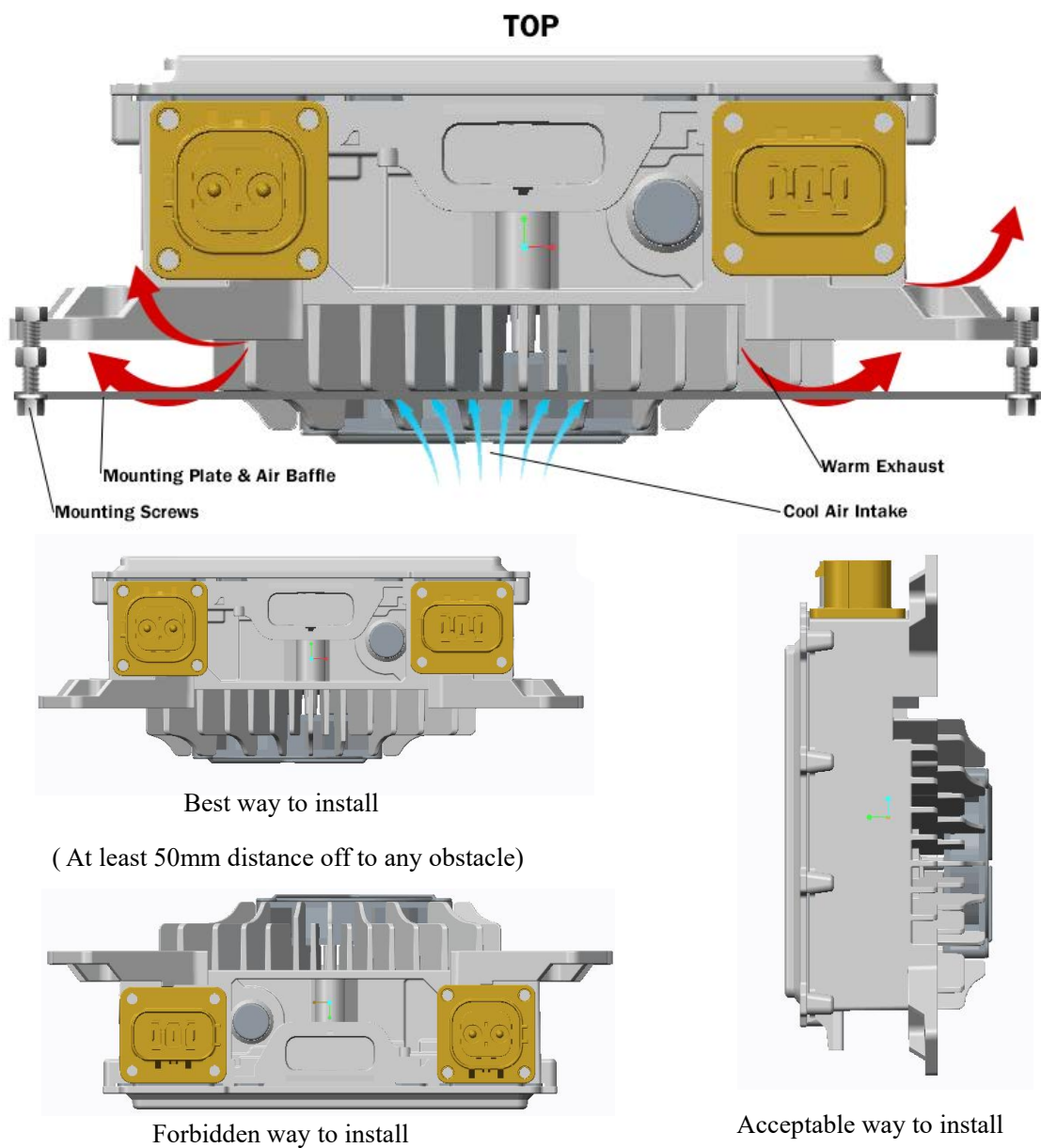

---

## 11 Safety Guide

Warning: remind the user that the operation is dangerous

- \* It is strictly prohibited to disassemble and refit the on-board charger for repair or commissioning
- \* Do not place the parts in the rain
- \* Please confirm that the housing is intact before installation. If it is damaged, please replace it immediately or contact the after-sales service department
- \* All plugs and sockets shall be connected firmly. If they are damaged or loose, please replace them immediately
- \* It is strictly prohibited to plug and unplug the connector when the product is powered on, otherwise personal injury may be caused
- \* It is strictly prohibited to open the product shell during the power on operation of the product, otherwise personal injury may be caused
- \* It is strictly forbidden to touch the high-voltage live parts of the product with bare hands. Please wear insulating gloves, insulating shoes Insulating clothing, live maintenance and detection are strictly prohibited
- \* During the replacement of fuses and contactors, rough handling is strictly prohibited to avoid damaging the product and causing potential safety hazards
- \* Three core cable with grounding wire shall be selected for AC power supply
- \* Please unplug the power plug if there is abnormal sound or smell during the operation of the charger
- \* Please keep away from fire sources and inflammables and explosives when the battery is normally charged
- \* Do not charge damaged or non rechargeable batteries

**Note: remind the user that the following operations are important operations of the product**

- \* Do not block the air inlet and outlet of the charger to prevent overheating
  - \* Please make sure that the output cable is not too long to avoid the impact of line voltage drop on charging
  - \* Please disconnect the power cord and charging plug when moving the charger
  - \* The battery voltage must be consistent with the nominal voltage of the charger
  - \* Avoid collision, compression, pulling, twisting or shaking the charging cable
  - \* The product should be placed in a safe, ventilated, dust-free and rain free environment
  - \* Please pack and store if not used for a long time
-